

Pressure booster DHS

KNOLL
.It works

Issue 08-2019



Properties

State-of-the-art screw pumps, valve and control technology

High- and low-pressure supply in a compact frame

Demand-controlled pump control

Modular toolbox system

Customer-specific design

Benefits

Low noise emissions

Low space requirement

Low electricity costs, great durability

Low costs and short delivery times

Best possible addressing of requirements

Application

The pressure booster DHS serves to supply machine tools with cooling lubricant. For this, low- and/or high-pressure pump(s) increase the supply pressure of a central plant. They supply all consumers of a machine tool with the necessary quantity of cooling lubricant. Examples are internally cooled tools and flushing.

Description

Main functions

1. Cleaning of the cooling lubricant to protect the high-pressure pump
2. Dividing of the cooling lubricant volumetric flow for the different pressure stages/consumers
3. Increasing of the input pressure
4. Cleaning of the cooling lubricant to protect the machine tool
5. Supplying of all consumers with the necessary quantity of cooling lubricant

Combination possibilities

For continuous adjustment of the required pressure, we equip the pumps with frequency control on request. This prevents pressure surges. Furthermore, it has a positive influence on energy consumption, durability and noise emission.

Equipment

Frame	●
High-pressure pump(s)	●
Low-pressure pump(s)	○
Piping and fittings	●
Sensor(s)	●
Protective filter for high-pressure pump	○
Protective filter for machine tool	○
Control	○

● Standard equipment

○ Option

Scheme

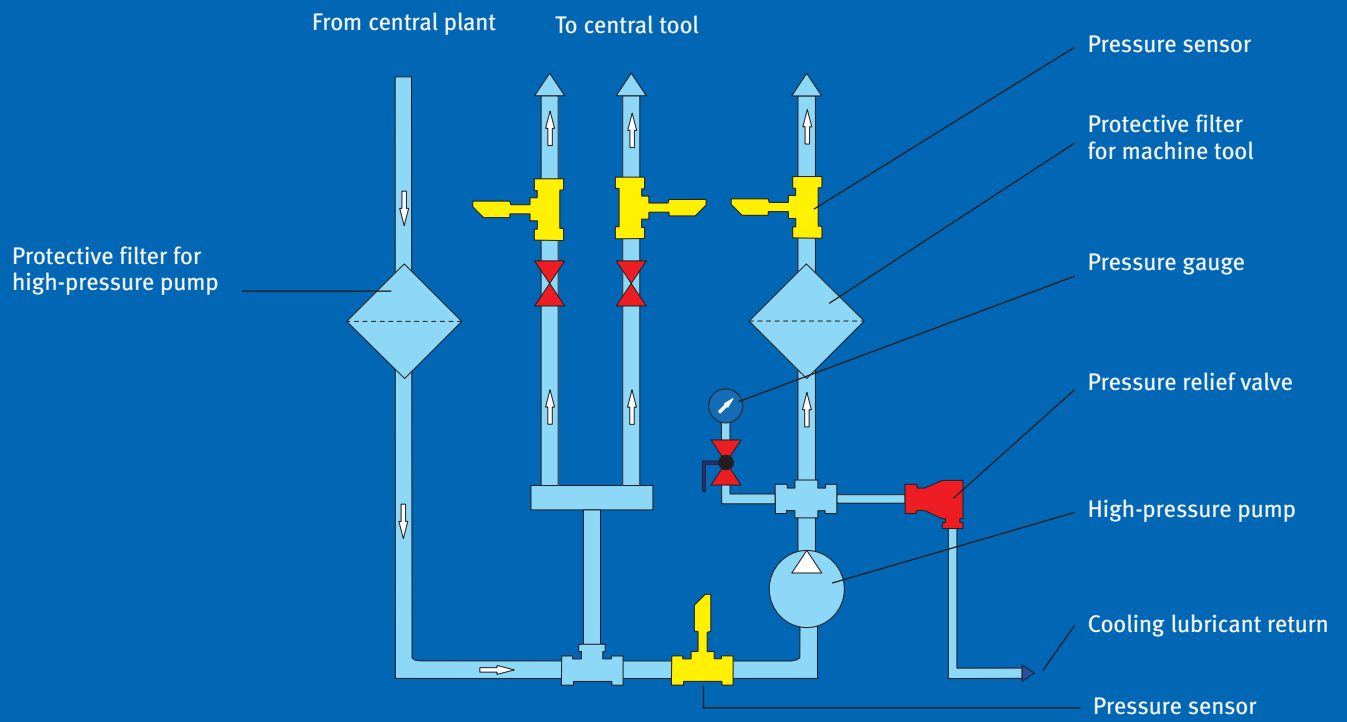

Design example

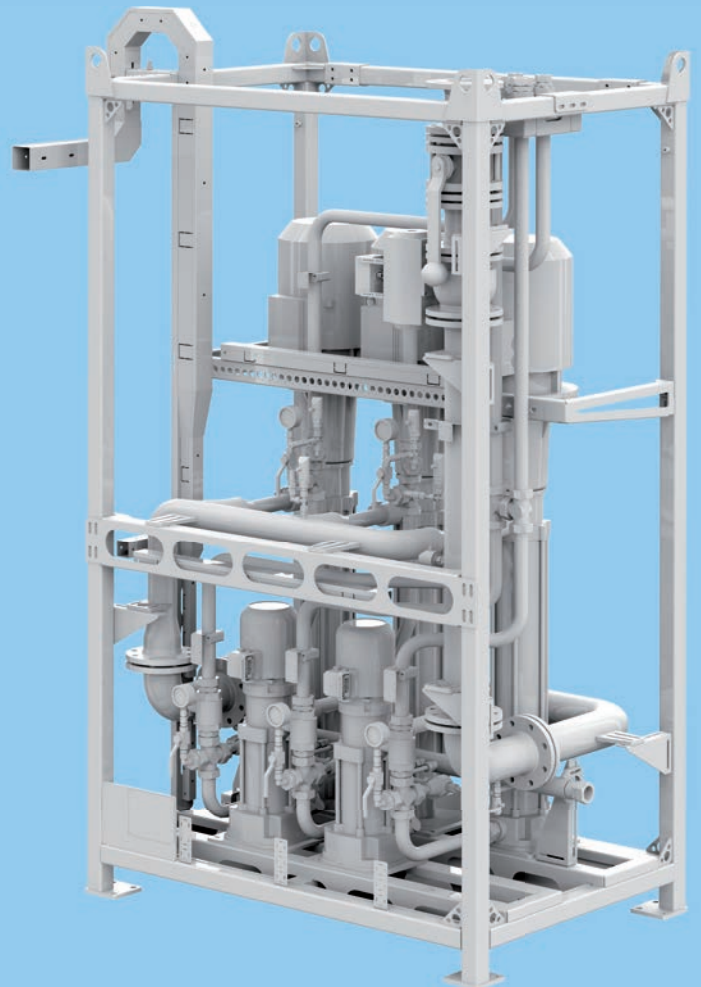

KNOLL Maschinenbau GmbH
Schwarzachstraße 20
DE-88348 Bad Saulgau
Tel. +49 7581 2008-0
Fax +49 7581 2008-90140
info.itworks@knoll-mb.de
www.knoll-mb.com

DHS

Dimensions

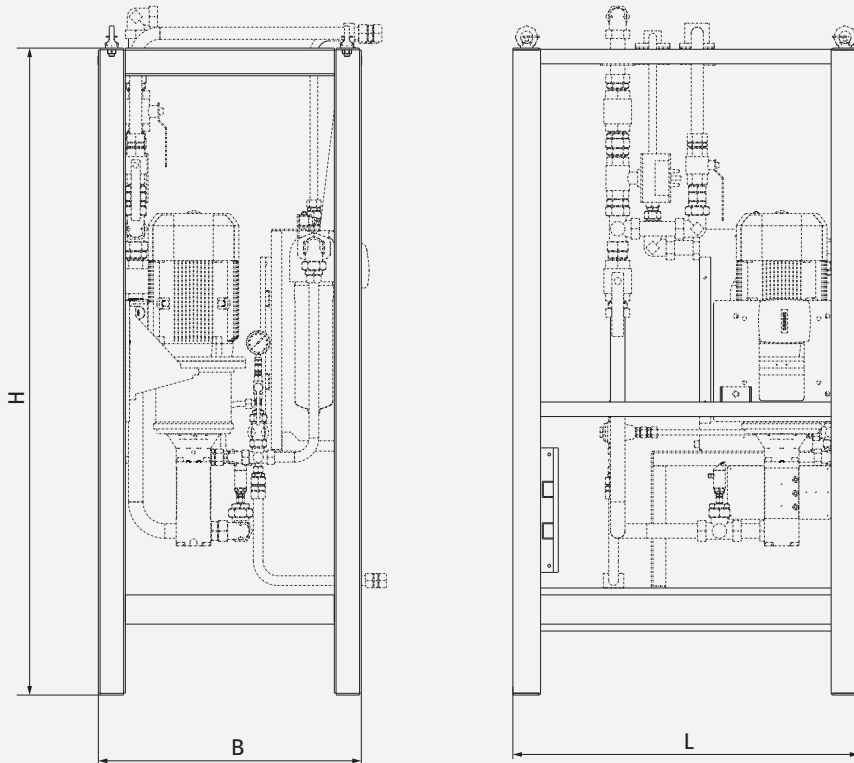

L	B	H
1000	760	1900
1200	600	1800

Dimensions without units given in mm.
Other dimensions on request.