

Chip reducer Z

**KNOLL**  
.It works

Issue 12-2022



## Content

Provided chip reducer with vertical chip feed.....	3
Chip reducer ZV-J (single shaft with double-faced blades).....	4
Chip reducer ZV-Z (single shaft with two-headed blades).....	5
Chip reducer ZVD-J and ZVDD-J (double shaft with double-faced blades).....	6
Chip reducer ZVDD-Z (double shaft with two-headed blades).....	7
Integrated chip reducer with horizontal chip feed.....	8
Chip reducer ZH-J (single shaft horizontal with double-faced blades).....	9
Chip reducer ZHV-J (single shaft vertical with double-faced blades).....	10
Design examples.....	11

## Properties

Suitable for different types of chips  
Wide, insensitive cutter  
Intake behavior regardless of the chip form  
Flexible, changeable toolbox system  
Easy, robust, and service-friendly layout  
Intelligent control  
Multiple sealing of the bearing units  
Low energy requirement

## Benefits

Many application possibilities  
Great durability  
Many application possibilities  
Easy modification  
Easy maintenance  
Great process reliability  
Great stability  
Low energy costs

## Areas of application

KNOLL chip reducers ZV, ZVD and ZVDD are machines for reducing metal and plastic chips. The chip feed is done vertically from above.

- Decentralized use on processing machines (retrofitable)
- Central use thanks to provision at collection points
- For volume reduction for improved bearing and transport properties of wool and winding chips
- For pre-treatment of the chips as pre-requisite for centrifuging, briquetting, melting, pumping, suction, etc.

## Description

### Main functions

1. Feeding of the chips in the feed hopper
2. Pulling in of the chips between the rotating cutter shaft and the angled infeed slide or fixed cutter
3. Crushing of the chips between the rotating and fixed cutter
4. Limitation of the chip lengths with screen insert with different hole sizes or without screen insert

### Variants

- Double-faced blades (-J): for large quantities of chips and high reducing quality
- Two-headed blades (-Z): with occurrence of problem parts and different types of chips
- Single shaft: for small bunches of chips and low to medium throughput
- Double shaft: for large or compressed bunches of chips and high throughput

### Combination possibilities

For other requirements, on request we can combine the chip reducers with

- Chip conveyors for feeding and removing the chips
- Frames for holding chip wagons
- Return pumping stations of chips and coolant lubricants to the central plant
- Extraction stations for transport of chips to the central plant
- Centrifuges and briquetting systems for further treatment of the chips
- Lift-tip devices for feeding the chips to central collection points

# Chip reducer ZV-J

Single shaft with  
double-faced blades

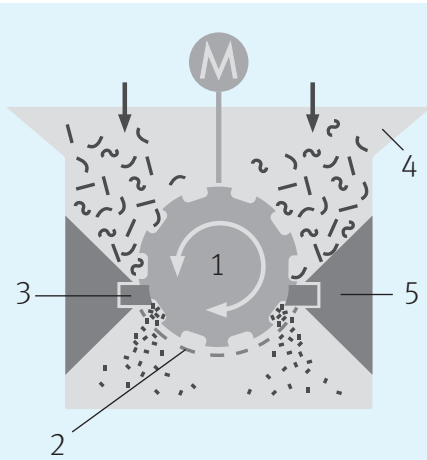

1. Rotating knife (double-faced blades)
2. Screen insert
3. Fixed cutter
4. Feed hopper
5. Angled infeed slide

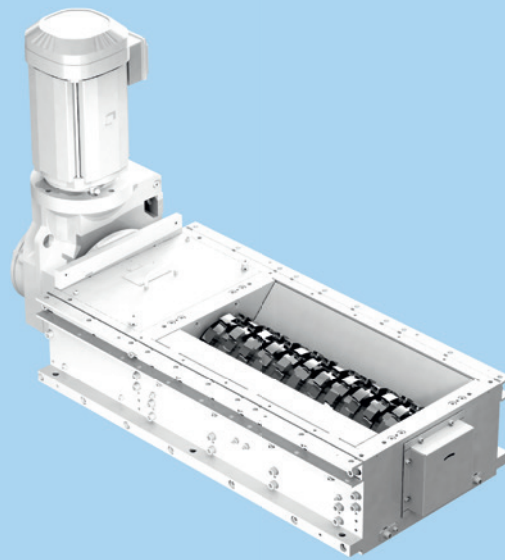

ZV 600-J

## Technical data

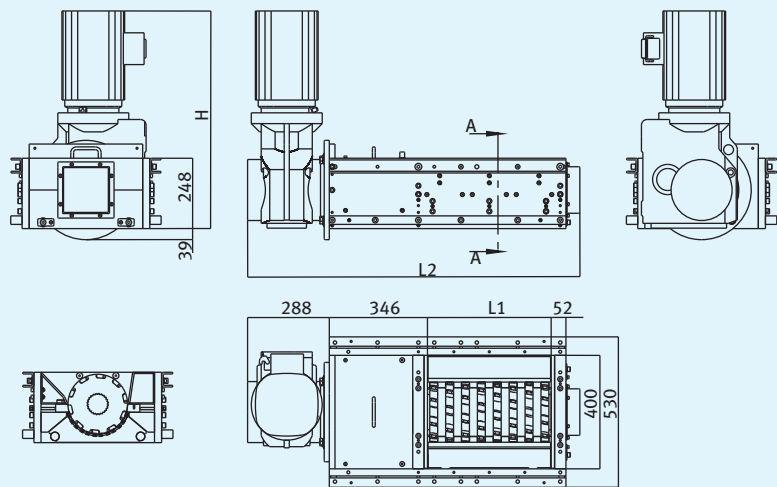

## Equipment

1 shaft	●
Double-faced blades (-J): 3-teeth	●
Fixed cutter	●
Drive 4.0 kW	●
Drive 5.5 kW	○
Screen insert with round holes $\varnothing$ 8-20	○

● Standard equipment  
○ Option

Type	Length L1	Length L2	Height H 4 kW / 5.5 kW	Max. throughput steel/ aluminum [kg/h] <sup>1</sup>	Max. bunch size
ZV 400-J	436	1176	770/820	100/50	250
ZV 600-J	636	1376	770/820	140/70	250

Dimensions without specification of units in mm | <sup>1</sup> Rough reference values for machines with sieve insert  $\varnothing$  14 mm for steel chips. The throughputs depend largely on the base material. We will be glad to perform cutting experiments.

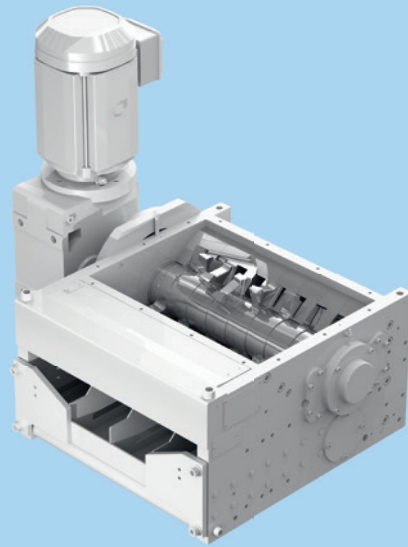

ZV 470-Z

## Chip reducer ZV-Z

Single shaft with two-headed blades

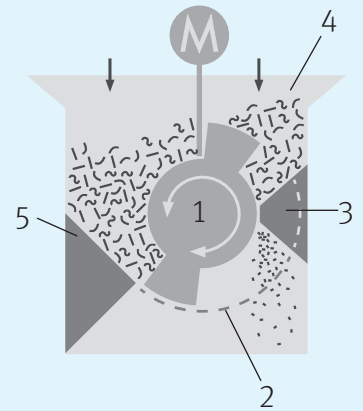

### Technical data

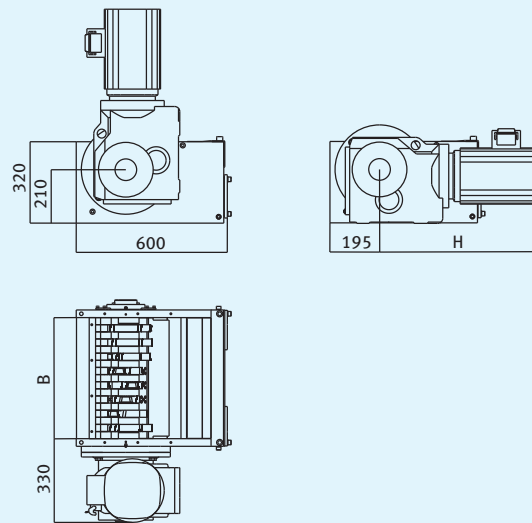

1. Rotating knife (two-headed blades)
2. Screen insert
3. Fixed cutter
4. Feed hopper
5. Angled infeed slide

### Equipment

1 shaft	●
Two-headed blades (-Z)	●
Fixed cutter	●
Screen insert with round holes $\varnothing$ 8-25	●
Drive 2.2 kW	●
Drive 4.0 kW	○

● Standard equipment  
○ Option

Type	Width B	Height H 2.2 kW / 4 kW	Max. throughput steel/ aluminum [kg/h] <sup>1</sup>	Max. bunch size
ZV 470-Z	476	555/635	60/30	300
ZV 600-Z	588	555/635	80/40	300

Dimensions without specification of units in mm | <sup>1</sup> Rough reference values for machines with sieve insert  $\varnothing$  14 mm for steel chips. The throughputs depend largely on the base material. We will be glad to perform cutting experiments.

# Chip reducer ZVD-J and ZVDD-J

Double shaft with  
double-faced blades

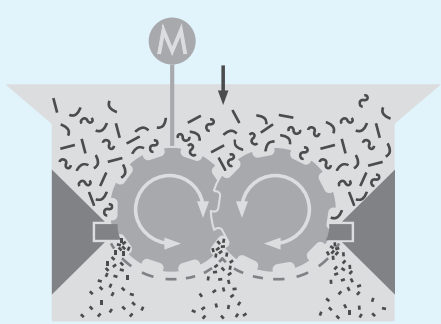

ZVD-J

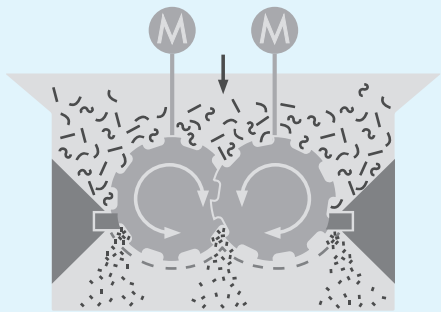

ZVDD-J

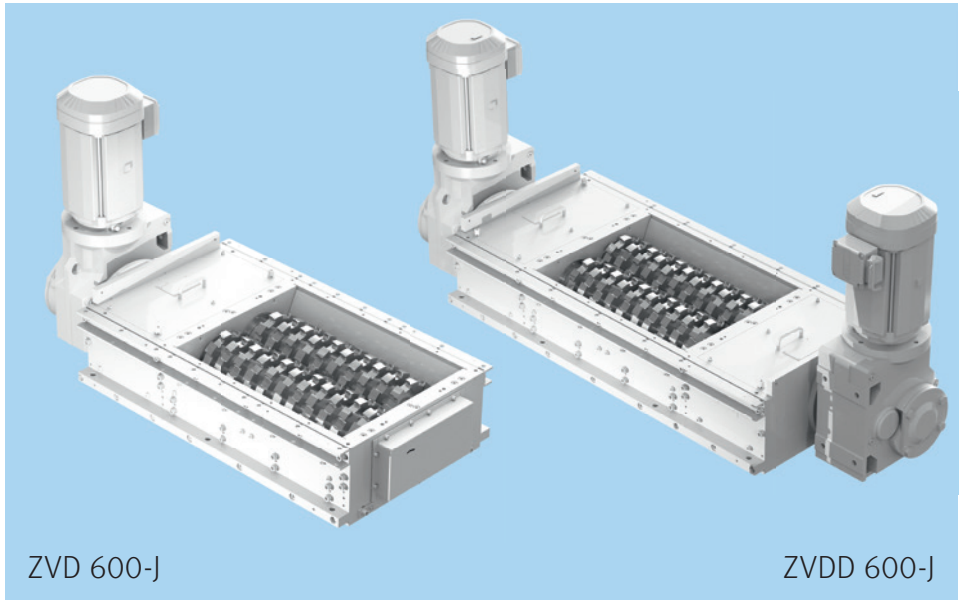

ZVD 600-J

ZVDD 600-J

## Technical data

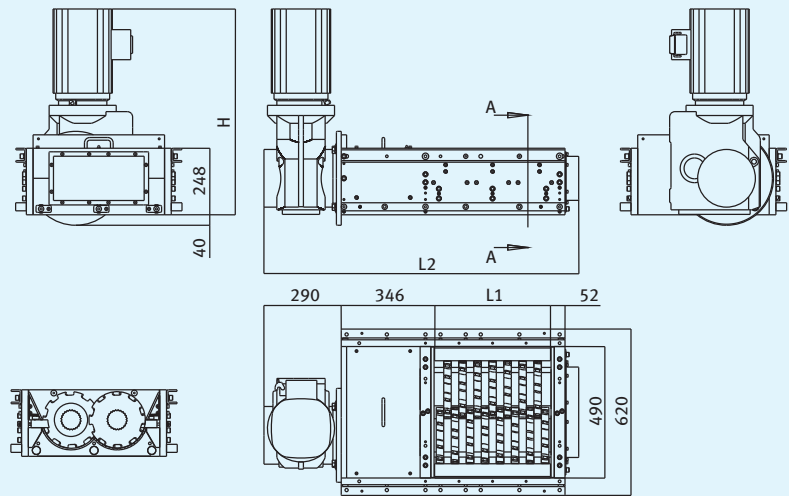

## Equipment

ZVD-J	
2 shafts, 1 drive	●
Double-faced blades (-j): 10-, 7- or 5-teeth	●
Fixed cutter	●
Drive 4.0 kW	●
Drive 5.5 kW	○
Screen insert with round holes Ø 8-20	○
Filler piece (without fixed cutter)	○

ZVDD-J	
2 shafts, 2 drives	●
Double-faced blades (-j): 10-, 7- or 5-teeth	●
Fixed cutter	●
Drive 4.0 kW (2x)	●
Drive 5.5 kW (2x)	○
Screen insert with round holes Ø 8-20	○
Filler piece (without fixed cutter)	○

● Standard equipment  
○ Option

Type	Length L1	Length L2	Height H 4 kW / 5.5 kW	Max. throughput steel/ aluminum [kg/h] <sup>1</sup>	Max. bunch size
ZVD 400-J	436	1176	770/820	120/60	350
ZVD 600-J	636	1376	770/820	160/80	350
ZVDD 600-J	636	1912	770/820	250/125	350

Dimensions without specification of units in mm | <sup>1</sup> Rough reference values for machines with sieve insert ø 14 mm for steel chips. The throughputs depend largely on the base material. We will be glad to perform cutting experiments.



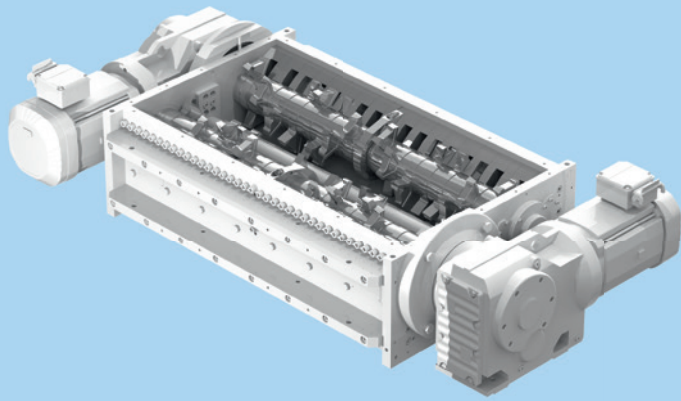

ZVDD 1000-Z

## Chip reducer ZVDD-Z

Double shaft with two-headed blades

### Technical data

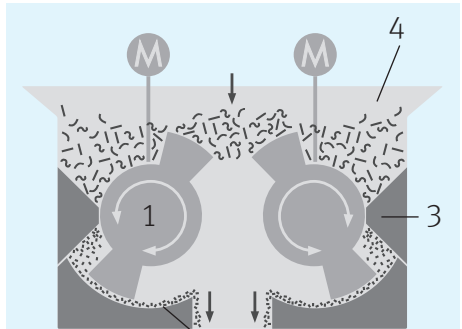
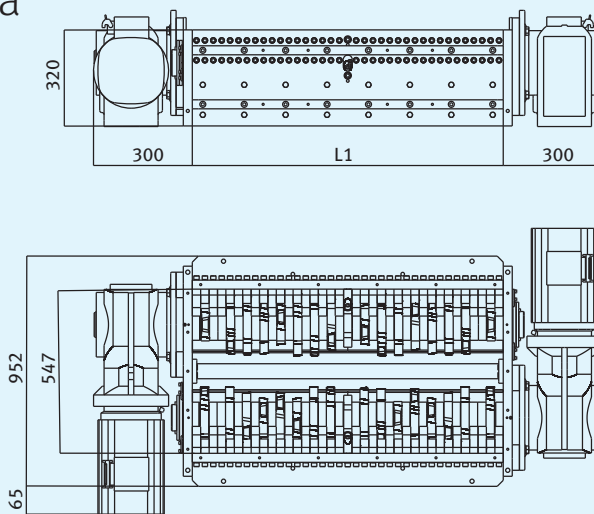

ZVDD-Z-F 5

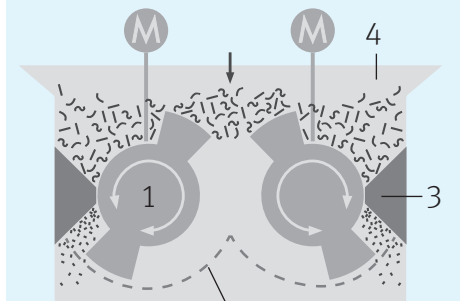

ZVDD-Z-G 2

### Equipment

- Standard equipment
- Option

- 2 shafts, 2 drives ●
- Two-headed blades (-Z) ●
- Fixed cutter ●
- Drive 4.0 kW (2x) ●
- Central lubrication ●
- Optional screen insert with round holes Ø 12, 16, 20, long hole (-G) or form shell (open version; -F) ●

1. Rotating knife (two-headed blades)
2. Screen insert
3. Fixed cutter with integrated angled infeed slide
4. Feed hopper
5. Shell mould

Type	Length L1	Max. throughput steel/ aluminum [kg/h] <sup>1</sup>	Max. bunch size
ZVDD 600-Z-G	588	300/150	500
ZVDD 600-Z-F	588	600/300	500
ZVDD 1000-Z-G	1036	600/300	500
ZVDD 1000-Z-F	1036	1200/600	500

Dimensions without specification of units in mm | <sup>1</sup> Rough reference values for machines with sieve insert Ø 16 mm for steel chips. The throughputs depend largely on the base material. We will be glad to perform cutting experiments.

## Properties

Suitable for different types of chips

Robust cutter

Intake behavior regardless of the chip form

Can be integrated compactly into return pumping stations

Easy, robust, and service-friendly layout

Intelligent control

Multiple sealing of the bearing units

Low energy requirement

## Benefits

Many application possibilities

Great durability

Many application possibilities

Space-saving

Easy maintenance

Great process reliability

Great stability

Low energy costs

## Areas of application

KNOLL chip reducers ZH-J and ZHV-J are machines for the reduction of metal and plastic chips. Chip feed is done horizontally.

- Especially as integrated component of the return pump station RIK
- Decentralized use on processing machines with close-to-floor chip feed via screw conveyor
- For volume reduction for improved bearing and transport properties of wool and winding chips
- For pre-treatment of the chips as pre-requisite for centrifuging, briquetting, melting, pumping, suction, etc.

## Description

### Main functions

1. Feed of the chips horizontally via screw conveyor
2. Pulling in of the chips by the rotating cutter shaft
3. Crushing between the chips between the rotating and fixed cutter
4. Limitation of the chip lengths by the perforated plate with different hole sizes and the chip holding back classifier disk

### Combination possibilities

For other requirements, on request we can combine the chip reducers with

- Return pumping station RIK for transport of chips to the central plant
- Screw conveyor for feeding of the chips
- Chip conveyor for removing the chips



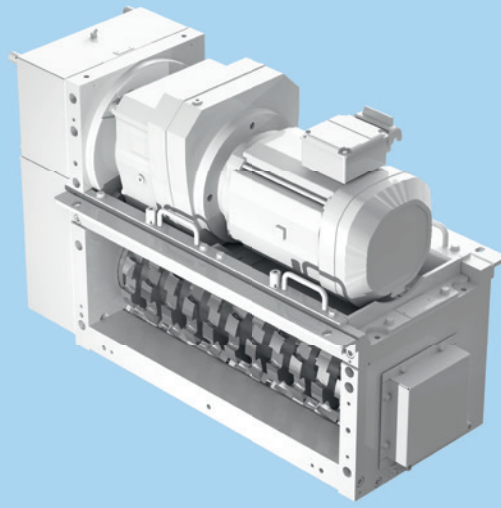

ZH 600-J

## Chip reducer ZH-J

Double shaft horizontal with  
double-faced blades

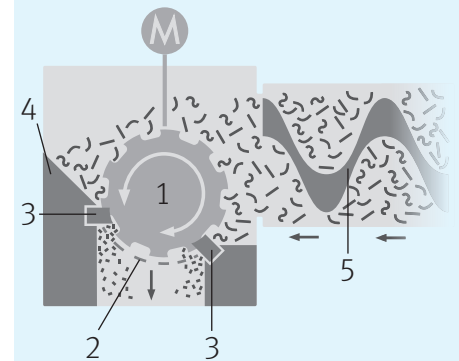

### Technical data

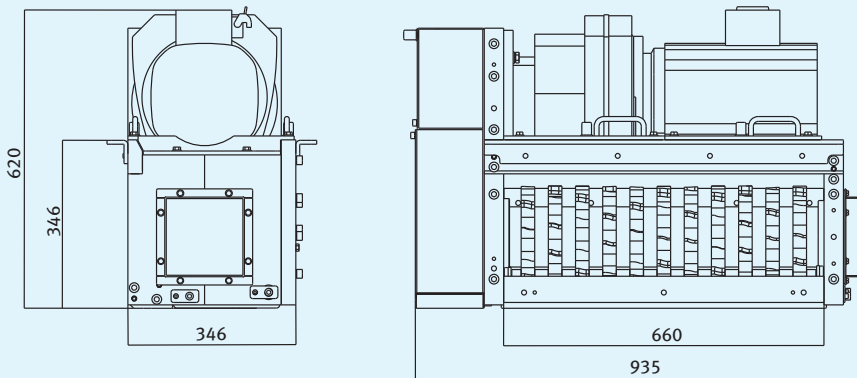

ZH-J

1. Rotating knife (double-faced blades)
2. Screen insert
3. Fixed cutter
4. Angled infeed slide
5. Feeding via screw (not integrated)

### Equipment

1 horizontal shaft	●
Double-faced blades (-): 3-teeth	●
Fixed cutter	●
Drive 4.0 kW	●
Screen insert with round holes $\varnothing$ 8, 10, 12 or 16	○

- Standard equipment
- Option

Type	Max. throughput steel/ aluminum [kg/h] <sup>1</sup>	Max. bunch size
ZH 600-J	120/60	200

Dimensions without specification of units in mm | <sup>1</sup> Rough reference values for machines with sieve insert  $\varnothing$  10 mm for steel chips. The throughputs depend largely on the base material. We will be glad to perform cutting experiments.

# Chip reducer ZHV-J

Single shaft vertical with  
double-faced blades

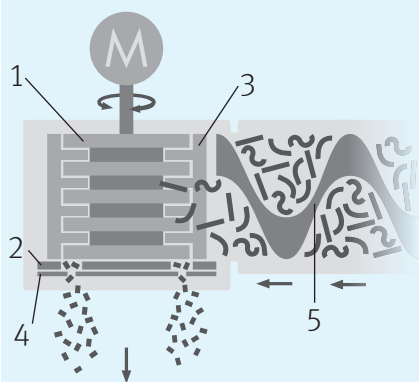

ZHV-J

1. Rotating knife (double-faced blades)
2. Perforated plate
3. Fixed cutter
4. Separator disc
5. Feeding via screw (not integrated)

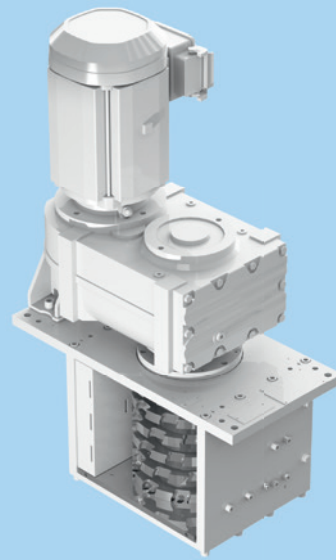

ZHV 350-J

## Technical data

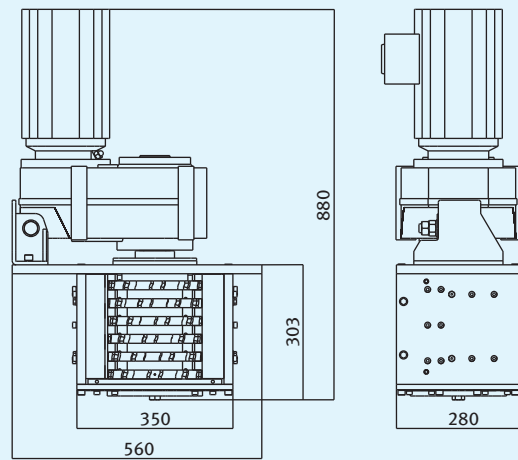

## Equipment

Double-faced blades (-J): 3-teeth	●
Fixed cutter	●
Drive 3.0 kW	●
Perforated plate with long holes 10 x 14, 12.5 x 20 or 17 x 32	●

- Standard equipment
- Option

Type	Max. throughput steel/ aluminum [kg/h] <sup>1</sup>	Max. bunch size
ZHV 350-J	60 / 30	200

Dimensions without specification of units in mm | <sup>1</sup> Rough reference values for machines with perforated plate 12.5 x 20 mm for steel chips. The throughputs depend largely on the base material. We will be glad to perform cutting experiments.

## Design examples



Chip reducer ZVD 400-J  
on a frame for volume reduction

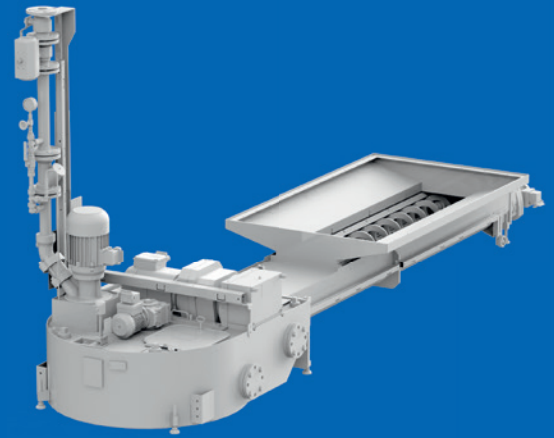

Chip reducer ZH 600-J in a  
return pumping station RIK

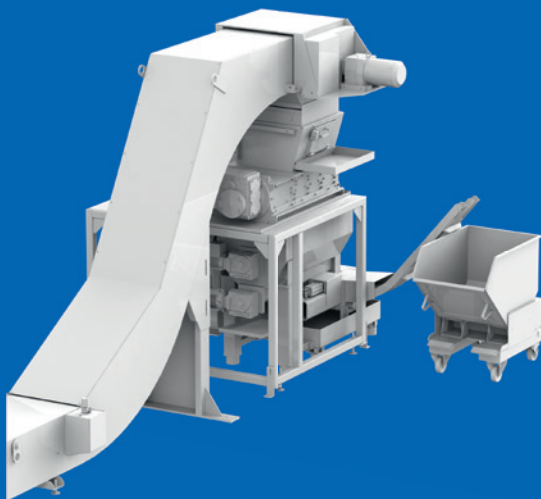

Chip reducer ZVD 600-J in a chip  
treatment system with briquetting  
system

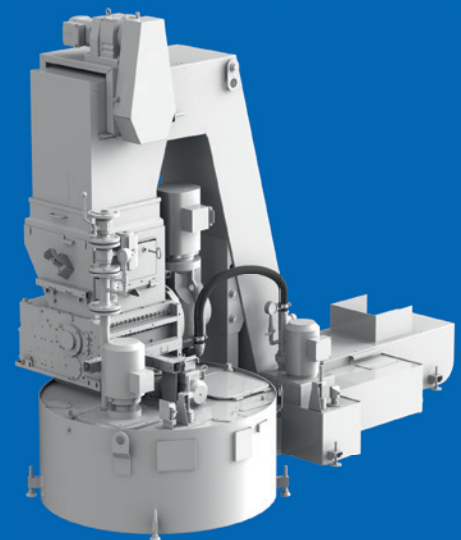

Chip reducer ZV 470-Z in a return  
pumping station RKR

**KNOLL Maschinenbau GmbH**

Schwarzachstraße 20

DE-88348 Bad Saulgau

Tel. +49 7581 2008-0

Fax +49 7581 2008-90140

info.itworks@knoll-mb.de

www.knoll-mb.com

